

VKO AXIAL SERIES

• Application

The Fanco VKO series are designed for supply and exhaust ventilation of premises requiring low to medium airflow at low air resistance. The fans are compatible with round duct with models in 100mm, 125mm and 150mm.

• About the motor

The VKO features a reliable low watt electric motor. All motors are single phase, include overheating protection and are designed for continuous operation. The motor is IPX4 rated.

• Mounting

The fan comes with a fixing bracket and can be mounted horizontally or vertically on a flat surface.



SKU	Description
EXVUVK01	VKO 100mm Axial Inline Fan
EXVUVK02	VKO 125mm Axial Inline Fan
EXVUVK03	VKO 150mm Axial Inline Fan

Fan Overall Dimensions (mm)

	EXVUVK01	EXVUVK02	EXVUVK03
D	100	125	150
D1	104	129	154
L	91	93	108
L1	31	31	46
H	114	139	163
B	160	185	200
B1	144	169	184
L2	45	45	45
L3	29	29	29

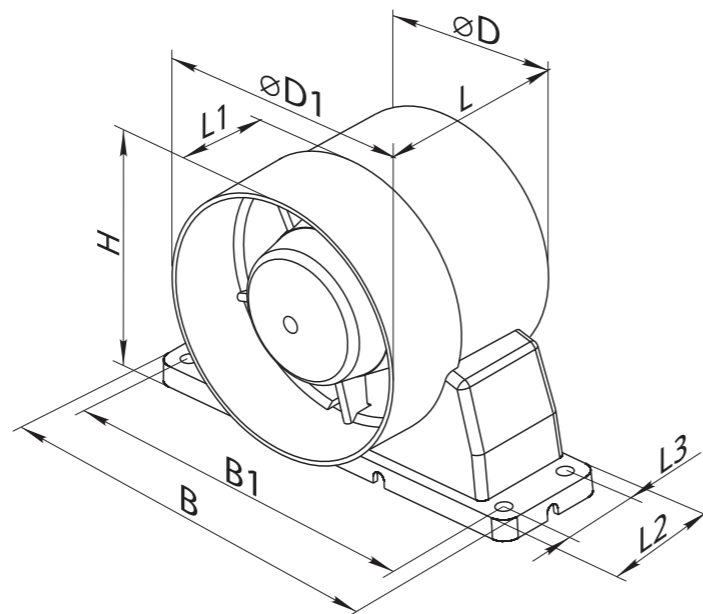

EXVUVK01 - VKO 100mm Axial Inline Fan

Voltage	220-240
Power (W)	16
Current (A)	0.1
Capacity (m3/hr)	135
Capacity (l/s)	37.53
Capacity (CFM)	79.51
RPM (min-1)	2300
Noise Level at 3m (dBA)	38
Protection rating	IPX4

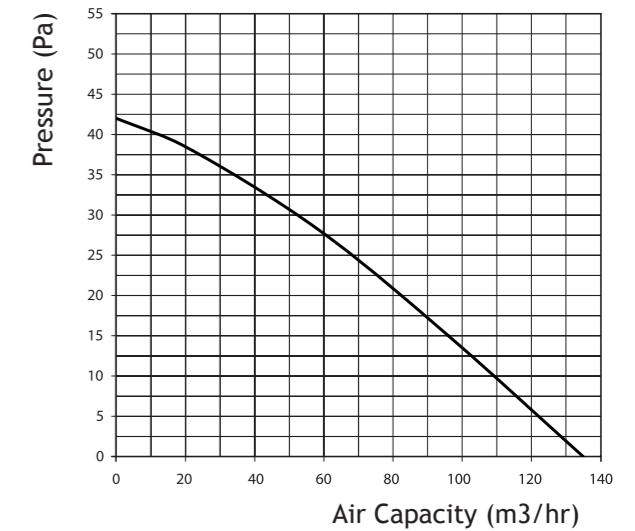

EXVUVK02- VKO 125mm Axial Inline Fan

Voltage	220-240
Power (W)	24
Current (A)	0.105
Capacity (m3/hr)	243
Capacity (l/s)	67.55
Capacity (CFM)	143.12
RPM (min-1)	2400
Noise Level at 3m (dBA)	39
Protection rating	IPX4

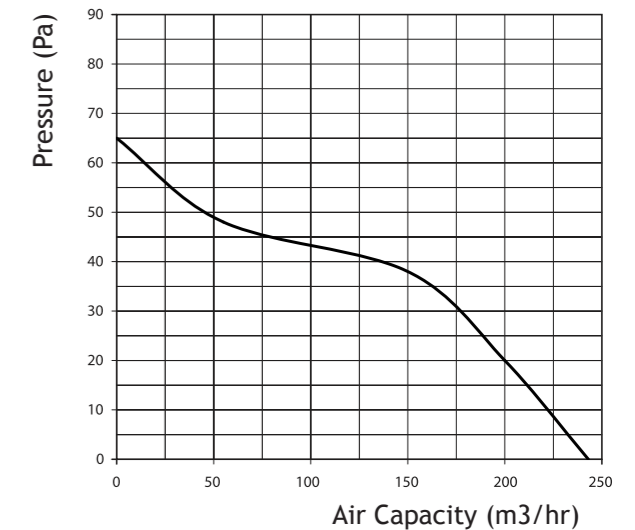

EXVUVK03 - VKO 150mm Axial Inline Fan

Voltage	220-240
Power (W)	29
Current (A)	0.13
Capacity (m3/hr)	358
Capacity (l/s)	99.52
Capacity (CFM)	210.86
RPM (min-1)	2400
Noise Level at 3m (dBA)	44
Protection rating	IPX4

