

TT SILENT MIXFLOW SERIES

• Application

The Fanco TT series are designed for supply and exhaust ventilation of premises requiring high pressure and powerful airflow at a very low noise level. The fans are compatible with round duct with models in 150mm and 200mm.

• About the motor

All motors are equipped with a single phase motor with two selectable speeds. All motors have thermal overheating protection, ball bearings which ensure a motor life expectancy of 40,000 hours at non stop operation. The motor is IPX4 rated.

• About the Design

The external casing is made from polymer coated steel. The housing has an internal heat and sound insulating layer with 50mm mineral wool. This results in lower decibel figures.



Speed Controller



This fan can be used with the ESVUP31 positional controller

SKU	Description
EXVUTTS150	TT Silent 150mm Mixflow Inline Fan
EXVUTTS200	TT Silent 200mm Mixflow Inline Fan

Fan Overall Dimensions (mm)

SKU	D	B	B1	L	H
EXVUTTS150	147	247	274	580	260

SKU	D	B	B1	L	H
EXVUTTS200	198	293	386	550	295

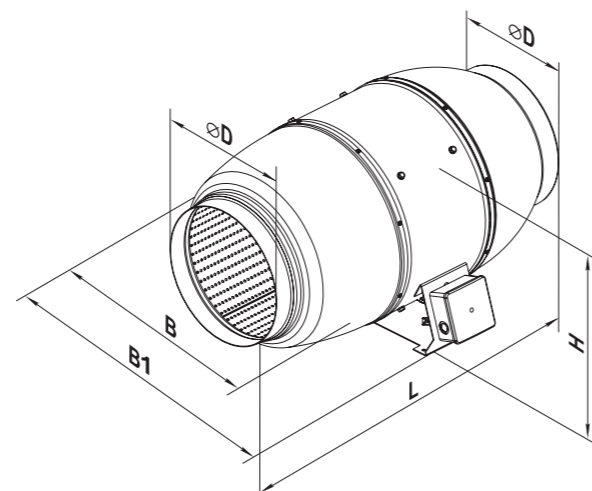
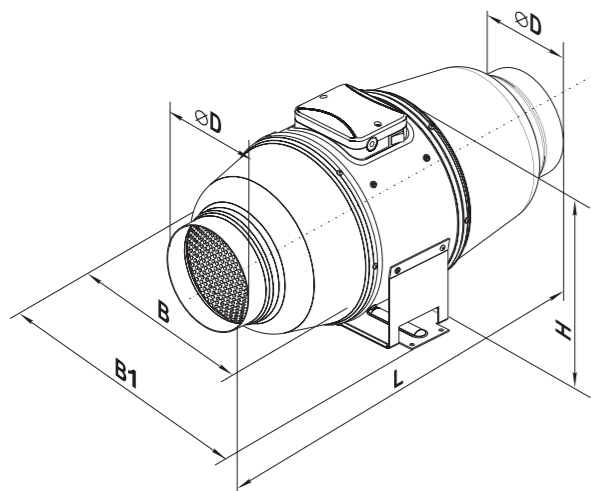

EXVUTTS150 - TT Silent 150mm Mixflow Inline Fan

Speed	Min	Max
Voltage	230	230
Power (W)	45	52
Current (A)	0.2	0.23
Capacity (m3/hr)	405	555
Capacity (l/s)	112.59	154.29
Capacity (CFM)	238.54	326.89
RPM (min-1)	1970	2645
Noise Level at 3m (dBA)	26	33
Max air temp (°C)	60	60
Protection rating	IPX4	IPX4

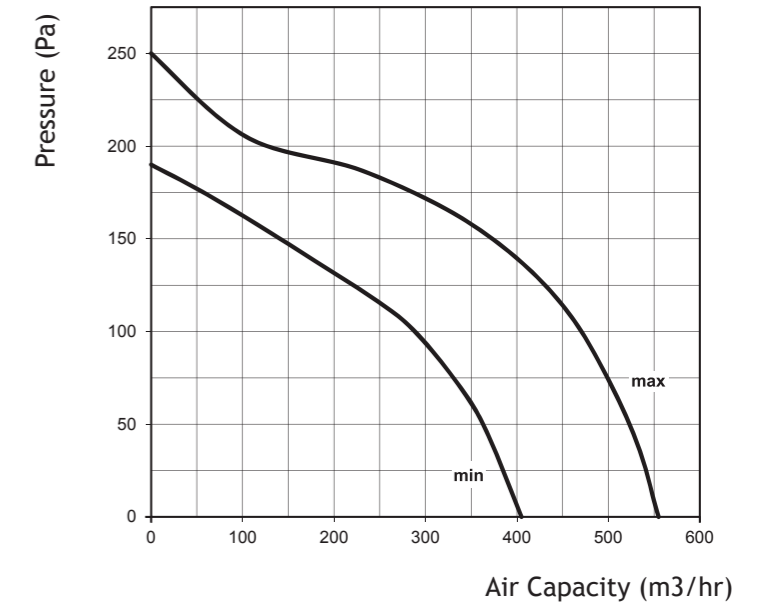

EXVUTTS200 - TT Silent 200mm Mixflow Inline Fan

Speed	Min	Max
Voltage	230	230
Power (W)	78	110
Current (A)	0.35	0.49
Capacity (m3/hr)	810	1020
Capacity (l/s)	225.18	283.56
Capacity (CFM)	477.09	600.78
RPM (min-1)	2015	2445
Noise Level at 3m (dBA)	31	36
Max air temp (°C)	60	60
Protection rating	IPX4	IPX4

